

**Ancon**<sup>®</sup>

# Ancon SSTC & STC Thermally Insulated Balcony Connectors

For Steel-to-Concrete Applications

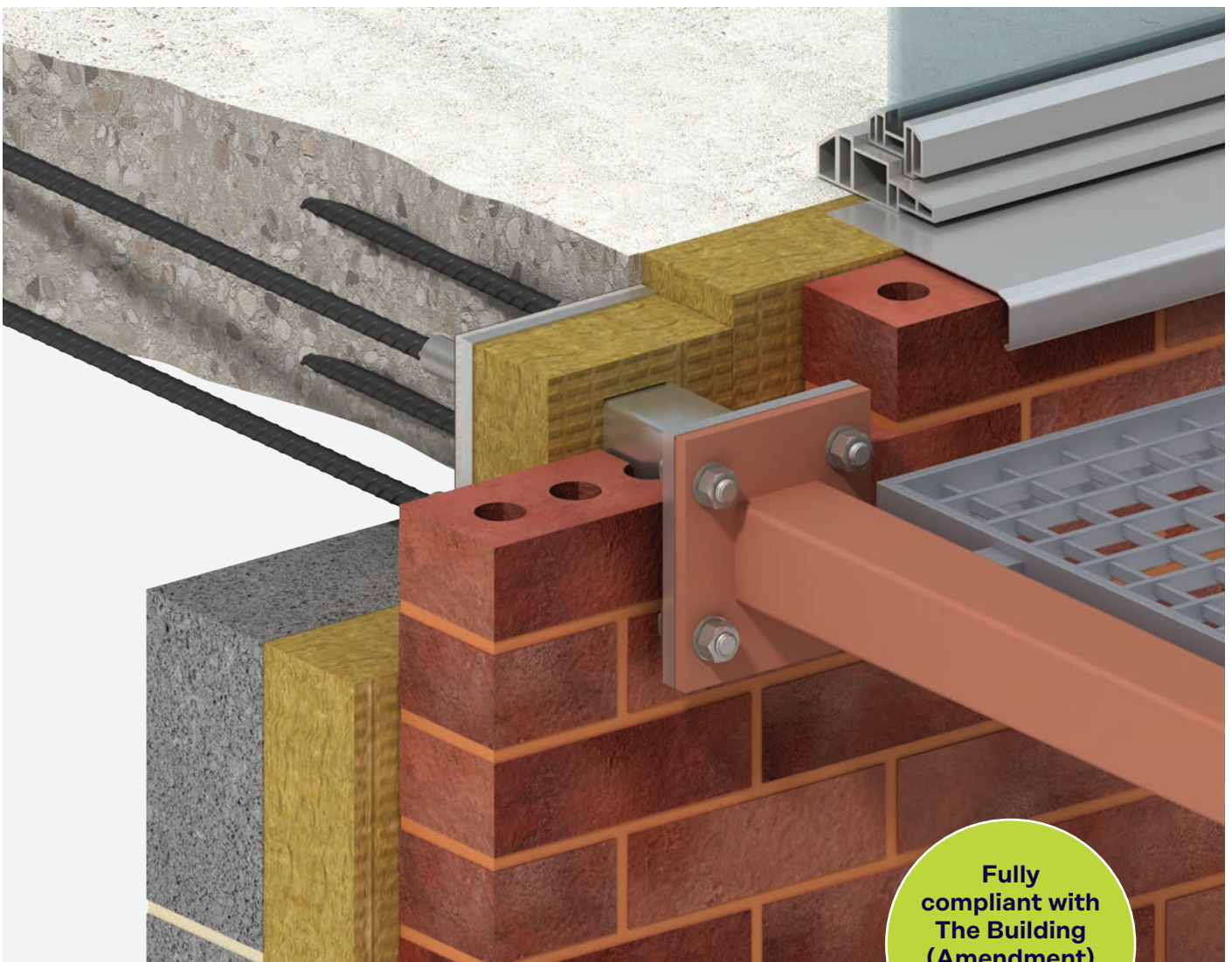

Fully  
compliant with  
The Building  
(Amendment)  
Regulations 2018

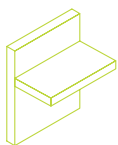

Structural Connections  
**Insulated Balcony Connectors**

# Leviat®

A CRH COMPANY

We imagine, model and make engineered products and innovative construction solutions that help turn architectural visions into reality and enable our construction partners to build better, safer, stronger and faster.

**Leviat is a world leader in connecting, fixing, lifting and anchoring technology.**

From the build of new schools, hospitals, homes and infrastructure, to the repair and maintenance of heritage structures, our engineering skills are making a difference around the world.

We provide technical design assistance at every stage of a project, from initial planning to installation and beyond.

Our technical support services range from simple product selection through to the development of a fully customised project-specific design solution.

Every promise we make locally, has the commitment and dedication of our global team behind it. We employ almost 3,000 people at 60 locations across North America, Europe and Asia-Pacific, providing an agile and responsive service worldwide.

**Leviat, a CRH company, is part of the world's leading building materials business.**



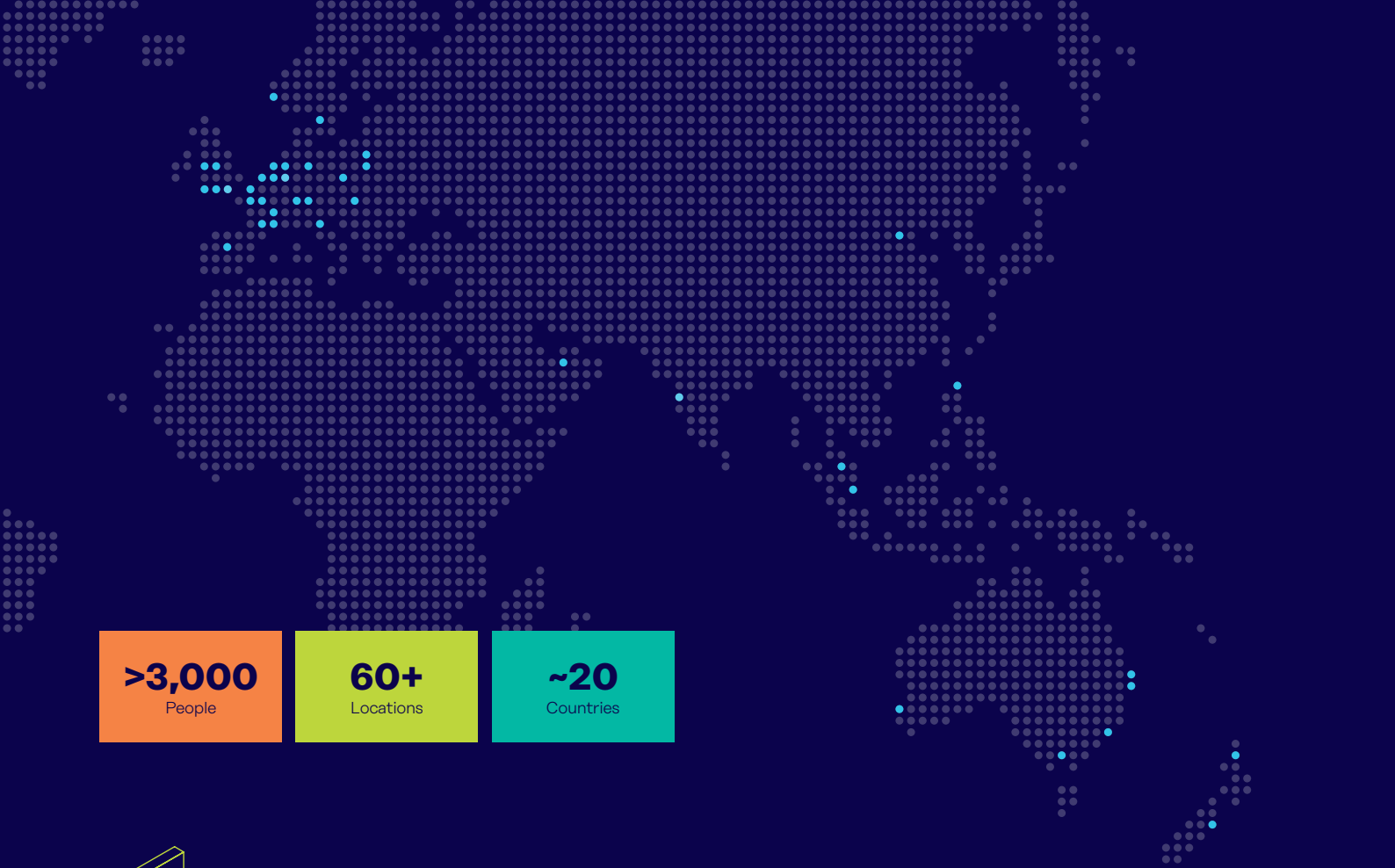

**>3,000**  
People

**60+**  
Locations

**~20**  
Countries

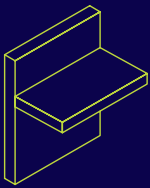

### Structural Connections

Systems to form robust, efficient connections, and continuity of concrete reinforcement as necessary, between walls, slabs, columns, beams and balconies, providing structural integrity as well as enhanced thermal and acoustic performance.

- Insulated balcony connectors
- Reinforcing bar couplers
- Concrete Connections
- Reinforcement continuity systems
- Punching shear reinforcement
- Shear load connectors
- Floor Joint Systems
- Precast / Reinforced Columns
- Infrastructure Products
- Precast Connections
- Acoustic dowels and bearings
- Prestress

### Other areas of expertise:

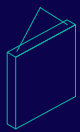

#### Lifting & Bracing

Systems for the safe and efficient transportation, lifting and temporary bracing of cast concrete elements and tilt-up panels before permanent structural connections are made.



#### Façade Support & Restraint

Systems for the safe and thermally-efficient fixing of the external building envelope, including brick and natural stone, insulated sandwich panels, curtain walling and suspended concrete façades, and also the repair and strengthening of existing masonry installations.



#### Anchoring & Fixing

Systems for fixing secondary fixtures to concrete, including anchor channels, bolts and inserts; also tension rod systems for roofs and canopies.



#### Formwork & Site Accessories

Non-structural accessories that complement our engineered solutions and help keep your construction environment operating safely and efficiently, including moulds for casting standard and special concrete elements and construction essentials such as reinforcing bar spacers.

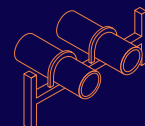

#### Industrial Technology

Mounting channels, pipe clamps and other versatile framing systems that provide safe fixing in a wide range of industrial applications.

### Leviat product ranges:

Ancon | Aschwanden | Connolly | Halfen | Helifix | Isedio | Meadow Burke | Modersohn | Moment | Plaka | Scaldex | Thermomass

# Ancon SSTC & STC Thermally Insulated Balcony Connectors

High integrity structural solutions to minimise cold bridging and its associated issues

## Contents

Introduction and SSTC	
Stainless Steel Range	6-7
SSTC Design Resistances	8-9
STC Carbon Steel Range	10
STC Design Resistances	11-13
Local Reinforcement	14-18
Corner Details	19-21
Installation Guidance	22-23
Other LeviaT Products	24

Energy efficiency is becoming increasingly important in today's sustainable building designs and the thermal performance of the building envelope is a key design consideration.

At the same time, architects are looking to create stylish, aesthetically appealing, mixed-use developments that combine high density occupancy with accessible outdoor space. Balconies often provide the answer, but as they typically pass through the building envelope, the fixing detail requires special attention to minimise thermal bridging and its various consequences, such as condensation and mould growth.

Thermal bridges occur where the insulation layer is penetrated by a material with a relatively high thermal conductivity.

Ancon Thermally Insulated Connectors minimise heat loss at balcony locations while maintaining structural integrity. They provide a thermal break by inserting a material with a low thermal conductivity between elements with a higher conductivity.

As a critical structural component, they transfer moment, shear, tension and compression forces.

Ancon Steel-to-Concrete Balcony Connectors are available with either carbon steel brackets (STC) or, for maximum thermal efficiency, stainless steel brackets (SSTC).



### UKCA and CE Marking

Construction products which fall within the scope of a Designated and harmonised standards should carry UKCA and CE marking under the Construction Products Regulation.

For steel fabrications like the Ancon SSTC/STC Balcony Connector, the harmonised standard is BS EN 1090-1 Execution of steel structures and aluminium structures: Requirements for conformity assessment of structural components. We comply with all UKCA and CE requirements of this standard including designs to EN 1993 (Eurocode 3) and external certification of our factory production controls by an approved body.



UKCA and CE Marked  
BS EN 1090-1  
BS EN 845-2



Free  
Design Service



BIM Objects  
Available



CPD Seminars  
Available

### Building Information Modelling

BIM objects of Ancon products are now available to download from either [www.ancon.co.uk/BIM](http://www.ancon.co.uk/BIM) or NBS Source.



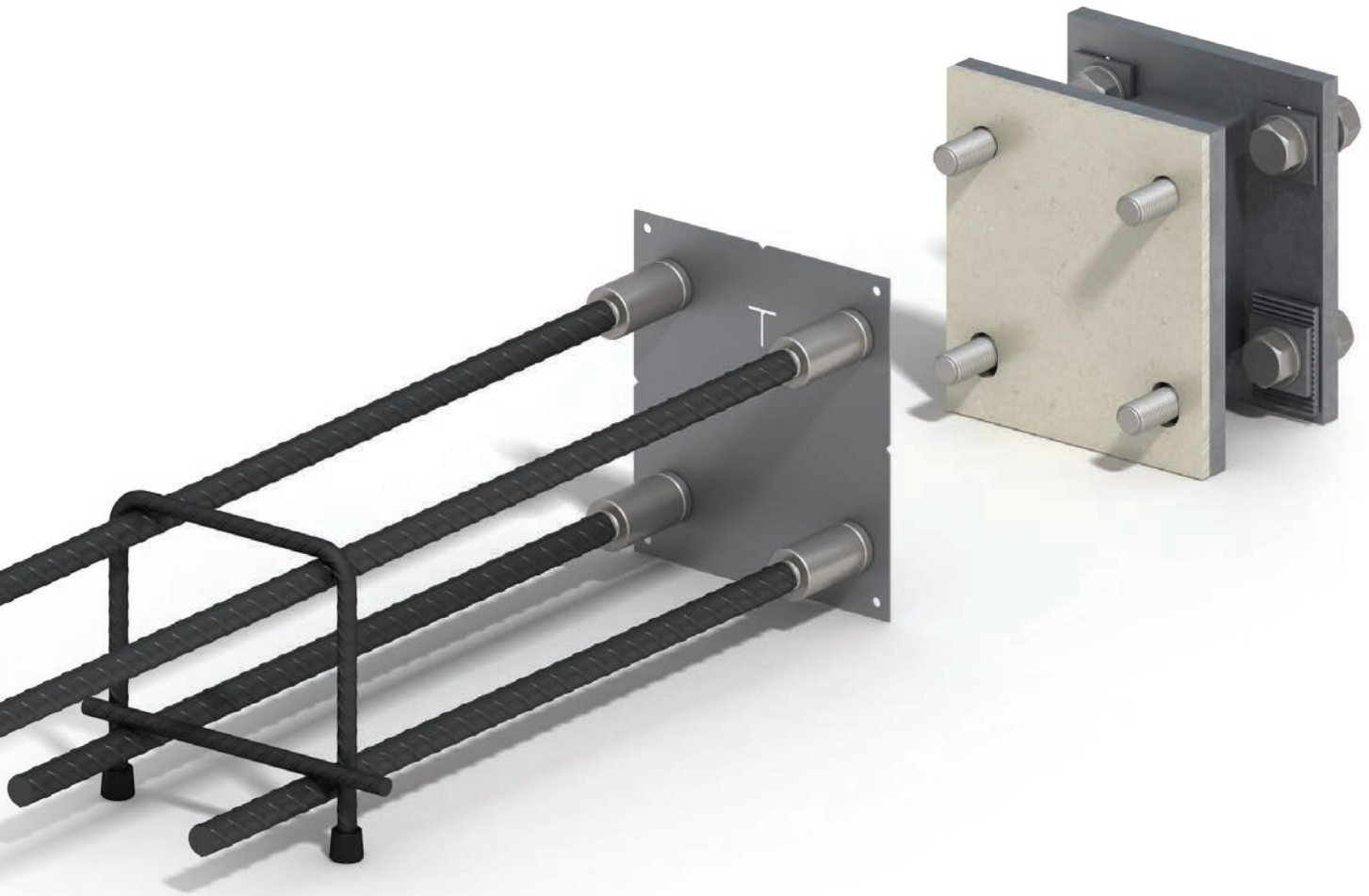

### **Material Combustibility**

Following a review of fire safety, the Government has banned the use of combustible materials in the external walls of high-rise residential buildings in England. The Ancon SSTC and STC connectors are fully compliant with the material combustibility requirements of The Building (Amendment) Regulations 2018. All components are either European classification A1 or A2-s1,d0. Contact us for further information.

### **Thermal Performance**

Thermal modelling of a typical insulated render wall application using Ancon SSTC and STC connectors confirms that the temperature factor is within the limits detailed in BRE document IP1/06 for eliminating condensation risk in dwellings, residential buildings, schools, offices and retail premises (0.75). In addition, the Ancon SSTC thermal report demonstrates suitability in higher humidity areas such as sports halls, kitchens and canteens (0.8). Contact us for further information.

# Ancon SSTC & STC Thermally Insulated Balcony Connectors

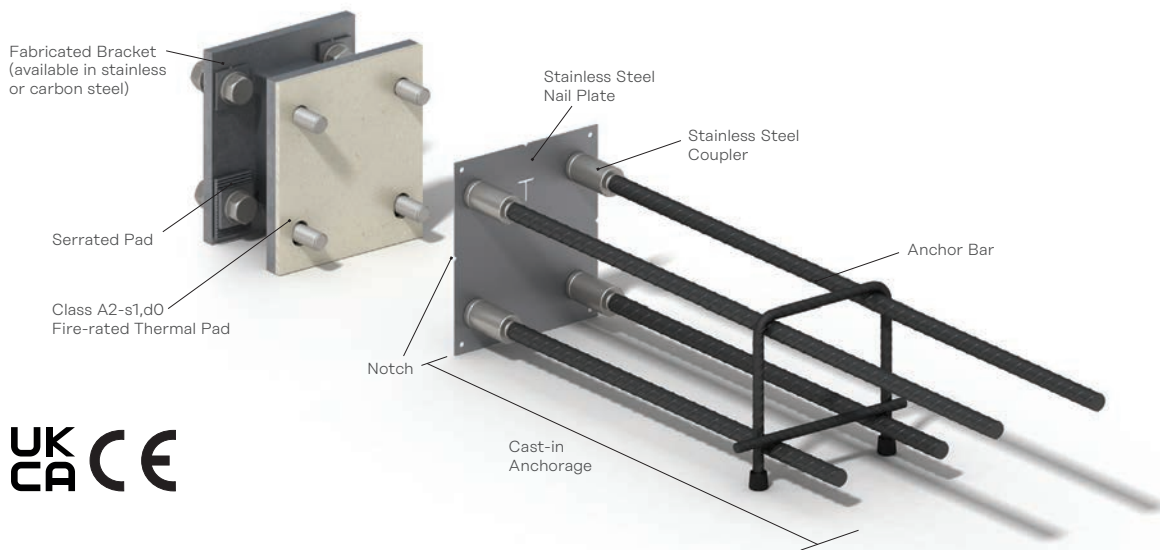

## Ancon SSTC and STC Balcony Connectors

The Ancon SSTC and STC range of steel-to-concrete balcony connectors is used to anchor steel balconies to concrete floor slabs and has been proven through thermal modelling to reduce heat loss when compared to direct connections.

The two-part assembly, comprising a cast-in anchorage and a post-fixed bracket with thermal pad located at the interface, allows for phased construction. Unlike one-piece systems which must be left exposed on-site for some time, the Ancon bracket component is not fixed until required, reducing the risk of damage.

Manufactured to order, bracket depth can be designed to suit the exact requirements of the application and avoid conflicts with the external cladding. The fabricated brackets are manufactured from either 1.4301 (304) stainless steel (SSTC) or hot-dip galvanised S355 plain carbon steel (STC). Stainless steel offers the greater thermal efficiency and is essential for applications requiring enhanced corrosion protection such as coastal areas. The brackets are designed to EN 1993 (Eurocode 3) and CE-marked to EN 1090 Part 1.

Serrated pads and slots provide vertical adjustment in the final bracket position without the need for stop butts or levelling shims.

The thermal plate has an independently verified European reaction-to fire classification of A2-s1,d0.

Anchor bars are Grade B500B and are supplied fixed to Duplex stainless steel couplers. Anchorage design conforms to BS EN1992.

A stainless steel nail plate completes the assembly and features side notches indicating the centreline, normally matched to the centreline of the slab, for accurate installation.

## System Benefits

- ✓ Comprises materials of class A1/A2 combustibility only, ideal for high-rise construction
- ✓ Proven through thermal modelling to reduce heat loss and eliminate condensation risk
- ✓ Two-part assembly allows phased installation and avoids damage by other trades
- ✓ Simple nailplate design avoids cutting of formwork around the connector
- ✓ Variable bracket projection to suit wall construction and avoid conflict with cladding
- ✓ Serrated slots provide vertical adjustment on-site for fine tuning of balcony without levelling shims
- ✓ Bracket fabrication UKCA and CE marked to BS EN 1090-1
- ✓ Anchorage design conforms to BS EN1992
- ✓ Fully stainless steel option offers the ultimate corrosion protection / thermal efficiency benefits

## Ancon SSTC Connector Range (Stainless Steel Bracket)

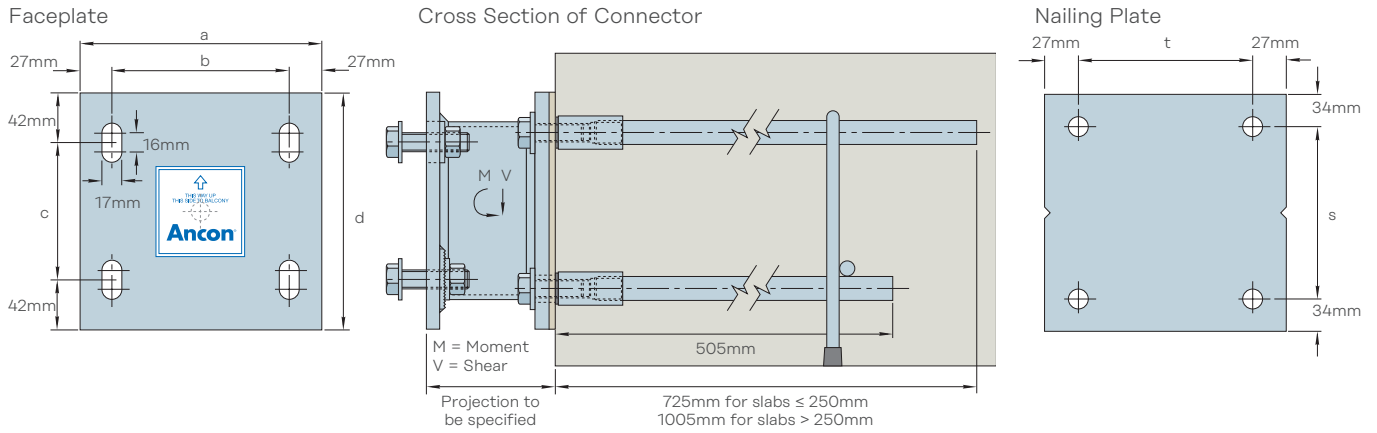

### Dimensions (mm)

Product Reference	Width a	Fixing Centres b	Fixing Centres c	Height d	Anchorage Spacing s	Anchorage Spacing t
SSTC16A-150	184	130	66	150	82	130
SSTC16A-175	204	150	91	175	107	150
SSTC16A-200	204	150	116	200	132	150
SSTC16A-225	204	150	141	225	157	150

**Note:** Recommended fixing bolt clearance hole diameter in balcony steelwork is 17mm.

### Product Referencing System

#### SSTC16A-150-320

Standard Stainless Steel Product Reference     Bracket Projection Reference

Carbon Steel equivalent:  
STC16A-150-320

# Ancon SSTC & STC Thermally Insulated Balcony Connectors

## Ancon SSTC Design Resistances\*

The following tables may be used to select the appropriate standard system. They are based on C32/40 concrete. For other concrete strengths, please contact us.

Leviat's Technical Services Team can advise on Ancon SSTC system design and operate in-house design software to provide recommendations for specific project requirements.

## Design Example

### Known requirements:

The Factored Ultimate Shear Force per connector,  $V_{Ed}$ , is 50kN  
The Factored Ultimate Moment per connector,  $M_{Ed}$ , is 15kNm  
The slab thickness is 275mm and concrete grade is C32/40  
The connector spacing is 750mm

### From the tables:

- ✗ SSTC16A-150 does not give the required capacity in a 275mm slab
- ✗ SSTC16A-175 gives  $V_{Rd} = 50\text{kN}$  and  $M_{Rd} = 13.99\text{kNm}$ , so it does not give the required capacity
- ✓ SSTC16A-200 gives  $V_{Rd} = 50\text{kN}$  and  $M_{Rd} = 15.58\text{kNm}$  and minimum centres <750mm
- ✗ SSTC16A-225 gives  $V_{Rd} = 50\text{kN}$  and  $M_{Rd} = 17.17\text{kNm}$  but centres >750mm

## Ancon SSTC16A-150

Design Shear Resistance $V_{Rd}$ (kN)	Minimum Connector Centres (mm)	Minimum Slab Edge Distance (mm)	Design Resistance for Bending $M_{Rd}$ (kNm)						
			175mm slab	200mm slab	225mm slab	250mm slab	275mm slab	300mm slab	325mm slab
36.02	520	260	11.38	11.38	11.38	11.38	11.38	11.38	11.38
39.21	560	280	-	11.38	11.38	11.38	11.38	11.38	11.38
42.47	595	300	-	-	11.38	11.38	11.38	11.38	11.38
45.81	630	315	-	-	-	11.38	11.38	11.38	11.38
46.07	670	335	-	-	-	-	11.38	11.38	11.38
49.21	670	335	-	-	-	-	10.72	10.72	10.72
50.00	710	355	-	-	-	-	-	10.55	10.55
52.70	710	355	-	-	-	-	-	9.99	9.99
55.00	750	375	-	-	-	-	-	-	9.51
56.25	750	375	-	-	-	-	-	-	9.25

## Ancon SSTC16A-175

Design Shear Resistance $V_{Rd}$ (kN)	Minimum Connector Centres (mm)	Minimum Slab Edge Distance (mm)	Design Resistance for Bending $M_{Rd}$ (kNm)						
			200mm slab	225mm slab	250mm slab	275mm slab	300mm slab	325mm slab	350mm slab
43.91	615	310	14.92	14.92	14.92	14.92	14.92	14.92	14.92
46.65	650	325	-	14.92	14.92	14.92	14.92	14.92	14.92
47.27	650	325	-	14.74	14.74	14.74	14.74	14.74	14.74
50.00	690	345	-	-	13.99	13.99	13.99	13.99	13.99
50.70	690	345	-	-	13.79	13.79	13.79	13.79	13.79
52.00	730	365	-	-	-	13.43	13.43	13.43	13.43
54.20	730	365	-	-	-	12.82	12.82	12.82	12.82
55.00	765	385	-	-	-	-	12.60	12.60	12.60
57.77	765	385	-	-	-	-	11.83	11.83	11.83
60.00	800	400	-	-	-	-	-	11.22	11.22
61.40	800	400	-	-	-	-	-	10.83	10.83
65.10	840	420	-	-	-	-	-	-	9.80

\*The provided design resistances apply exclusively to the complete system (cast-in anchorage and post-fixed bracket) as supplied by Leviat; any customer-produced components are not covered by our warranty or liability.



### Ancon SSTC16A-200

Design Shear Resistance $V_{Rd}$ (kN)	Minimum Connector Centres (mm)	Minimum Slab Edge Distance (mm)	Design Resistance for Bending $M_{Rd}$ (kNm)						
			225mm slab	250mm slab	275mm slab	300mm slab	325mm slab	350mm slab	375mm slab
46.00	690	345	16.80	16.80	16.80	16.80	16.80	16.80	16.80
50.00	690	345	15.58	15.58	15.58	15.58	15.58	15.58	15.58
50.70	690	345	15.36	15.36	15.36	15.36	15.36	15.36	15.36
54.20	730	365	-	14.28	14.28	14.28	14.28	14.28	14.28
55.00	770	385	-	-	14.03	14.03	14.03	14.03	14.03
57.77	770	385	-	-	13.18	13.18	13.18	13.18	13.18
61.40	800	400	-	-	-	12.06	12.06	12.06	12.06
65.10	840	420	-	-	-	-	10.92	10.92	10.92
68.85	880	440	-	-	-	-	-	9.76	9.76
70.00	920	460	-	-	-	-	-	-	9.40
72.67	920	460	-	-	-	-	-	-	8.58

### Ancon SSTC16A-225

Design Shear Resistance $V_{Rd}$ (kN)	Minimum Connector Centres (mm)	Minimum Slab Edge Distance (mm)	Design Resistance for Bending $M_{Rd}$ (kNm)						
			250mm slab	275mm slab	300mm slab	325mm slab	350mm slab	375mm slab	400mm slab
46.00	765	385	18.52	18.52	18.52	18.52	18.52	18.52	18.52
50.00	765	385	17.17	17.17	17.17	17.17	17.17	17.17	17.17
55.00	765	385	15.47	15.47	15.47	15.47	15.47	15.47	15.47
57.77	765	385	14.52	14.52	14.52	14.52	14.52	14.52	14.52
61.40	800	400	-	13.29	13.29	13.29	13.29	13.29	13.29
65.10	845	420	-	-	12.03	12.03	12.03	12.03	12.03
68.85	875	440	-	-	-	10.76	10.76	10.76	10.76
70.00	915	460	-	-	-	-	10.36	10.36	10.36
72.66	915	460	-	-	-	-	9.46	9.46	9.46
75.00	950	475	-	-	-	-	-	8.66	8.66
76.53	950	475	-	-	-	-	-	8.14	8.14
80.38	990	495	-	-	-	-	-	-	6.83

# Ancon SSTC & STC Thermally Insulated Balcony Connectors

## Ancon STC Connector Range (Galvanised Carbon Steel Bracket)

### Ancon STC16A Range

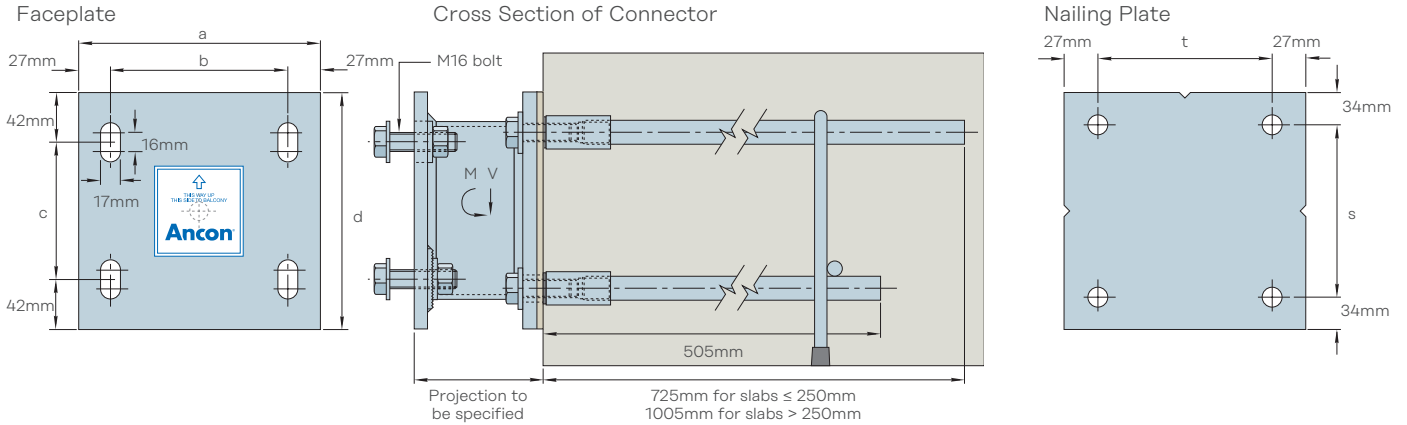

Product Reference	Width a	Fixing Centres b	Fixing Centres c	Height d	Anchorage Spacing s	Anchorage Spacing t
STC16A-150	184	130	66	150	82	130
STC16A-175	204	150	91	175	107	150
STC16A-200	204	150	116	200	132	150
STC16A-225	204	150	141	225	157	150

Recommended fixing bolt clearance hole diameter in balcony steelwork is 17mm.

### Ancon STC20A-200

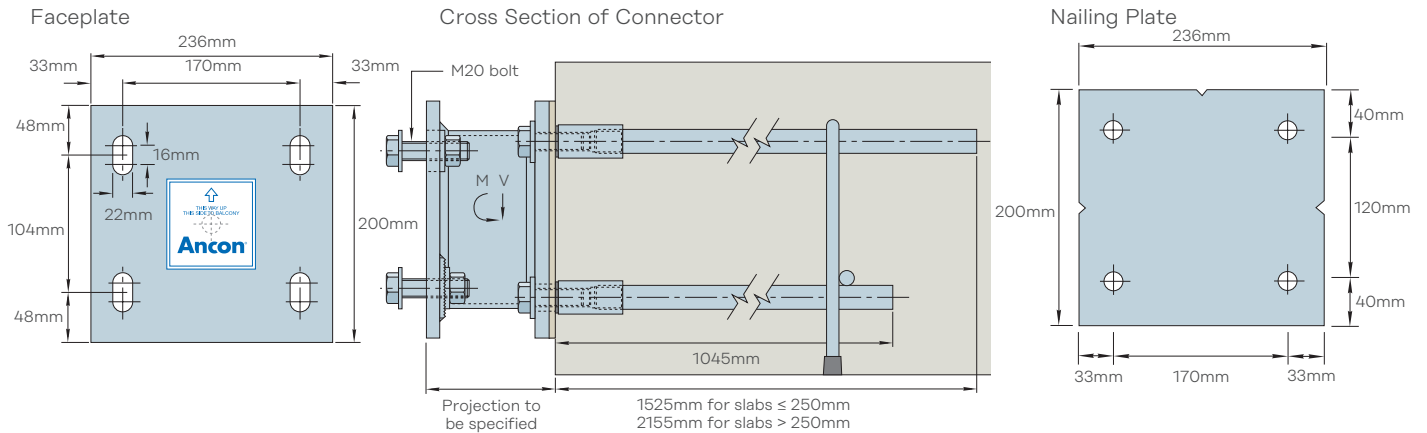

Recommended fixing bolt clearance hole diameter in balcony steelwork is 22mm.

### Ancon STC24A-240

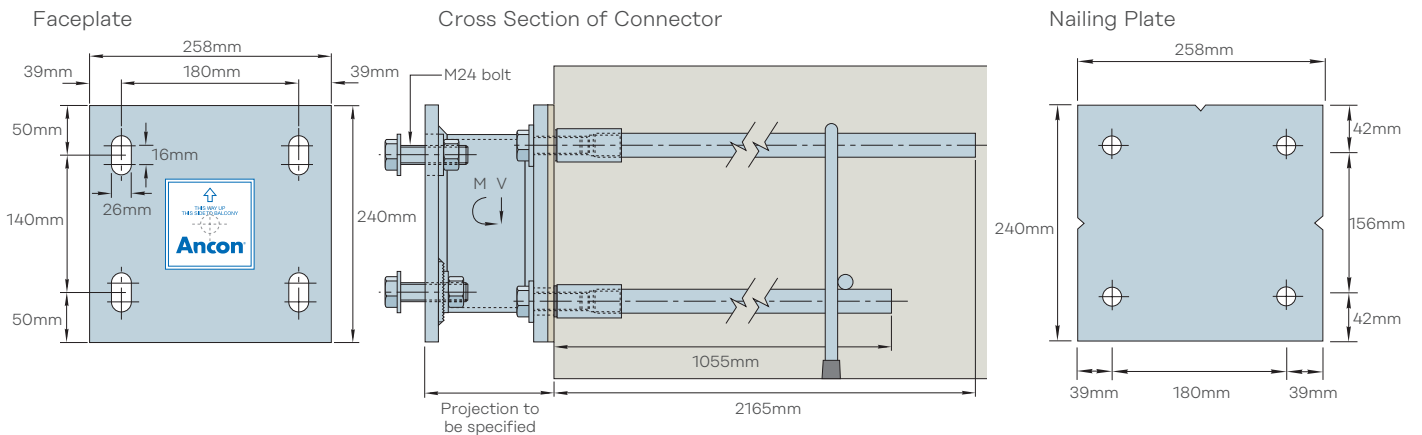

Recommended fixing bolt clearance hole diameter in balcony steelwork is 26mm.

## Ancon STC Design Resistances\*

The following tables may be used to select the appropriate standard system. They are based on a C32/40 concrete. For other concrete strengths, please contact us.

Leviat's Technical Services Team can advise on STC system design and operate in-house design software to provide recommendations for specific project requirements.

### Ancon STC16A-150

Design Shear Resistance $V_{Rd}$ (kN)	Minimum Connector Centres (mm)	Minimum Slab Edge Distance (mm)	Design Resistance for Bending $M_{Rd}$ (kNm)						
			175mm slab	200mm slab	225mm slab	250mm slab	275mm slab	300mm slab	325mm slab
36.02	520	260	13.75	13.75	13.75	13.75	13.75	13.75	13.75
39.21	560	280	-	13.75	13.75	13.75	13.75	13.75	13.75
41.68	595	300	-	-	13.75	13.75	13.75	13.75	13.75
42.47	595	300	-	-	13.61	13.61	13.61	13.61	13.61
45.81	630	315	-	-	-	13.03	13.03	13.03	13.03
49.21	670	335	-	-	-	-	12.43	12.43	12.43
50.00	710	355	-	-	-	-	-	12.30	12.30
52.70	710	355	-	-	-	-	-	11.83	11.83
55.00	750	375	-	-	-	-	-	-	11.42
56.25	750	375	-	-	-	-	-	-	11.21

### Ancon STC16A-175

Design Shear Resistance $V_{Rd}$ (kN)	Minimum Connector Centres (mm)	Minimum Slab Edge Distance (mm)	Design Resistance for Bending $M_{Rd}$ (kNm)						
			200mm slab	225mm slab	250mm slab	275mm slab	300mm slab	325mm slab	350mm slab
42.09	615	310	18.13	18.13	18.13	18.13	18.13	18.13	18.13
43.91	615	310	17.70	17.70	17.70	17.70	17.70	17.70	17.70
45.00	650	325	-	17.45	17.45	17.45	17.45	17.45	17.45
47.27	650	325	-	16.93	16.93	16.93	16.93	16.93	16.93
50.00	690	345	-	-	16.30	16.30	16.30	16.30	16.30
50.70	690	345	-	-	16.14	16.14	16.14	16.14	16.14
54.20	730	365	-	-	-	15.33	15.33	15.33	15.33
55.00	615	385	-	-	-	-	15.14	15.14	15.14
57.77	615	385	-	-	-	-	14.50	14.50	14.50
60.00	800	400	-	-	-	-	-	13.99	13.99
61.40	800	400	-	-	-	-	-	13.66	13.66
65.10	840	420	-	-	-	-	-	-	12.81

\*The provided design resistances apply exclusively to the complete system (cast-in anchorage and post-fixed bracket) as supplied by Leviat; any customer-produced components are not covered by our warranty or liability.

# Ancon SSTC & STC Thermally Insulated Balcony Connectors

## Ancon STC16A-200

Design Shear Resistance $V_{Rd}$ (kN)	Minimum Connector Centres (mm)	Minimum Slab Edge Distance (mm)	Design Resistance for Bending $M_{Rd}$ (kNm)						
			225mm slab	250mm slab	275mm slab	300mm slab	325mm slab	350mm slab	375mm slab
41.70	690	345	20.29	20.29	20.29	20.29	20.29	20.29	20.29
45.00	690	345	19.44	19.44	19.44	19.44	19.44	19.44	19.44
50.00	690	345	18.15	18.15	18.15	18.15	18.15	18.15	18.15
50.70	690	345	17.97	17.97	17.97	17.97	17.97	17.97	17.97
54.20	730	365	-	17.07	17.07	17.07	17.07	17.07	17.07
55.00	770	385	-	-	16.86	16.86	16.86	16.86	16.86
57.77	770	385	-	-	16.15	16.15	16.15	16.15	16.15
60.00	800	400	-	-	-	15.58	15.58	15.58	15.58
61.40	800	400	-	-	-	15.22	15.22	15.22	15.22
65.00	840	420	-	-	-	-	14.29	14.29	14.29
65.10	840	420	-	-	-	-	14.27	14.27	14.27
68.85	880	440	-	-	-	-	-	13.30	13.30
70.00	920	460	-	-	-	-	-	-	13.01
72.67	920	460	-	-	-	-	-	-	12.32

## Ancon STC16A-225

Design Shear Resistance $V_{Rd}$ (kN)	Minimum Connector Centres (mm)	Minimum Slab Edge Distance (mm)	Design Resistance for Bending $M_{Rd}$ (kNm)						
			250mm slab	275mm slab	300mm slab	325mm slab	350mm slab	375mm slab	400mm slab
41.70	765	385	22.36	22.36	22.36	22.36	22.36	22.36	22.36
45.00	765	385	21.42	21.42	21.42	21.42	21.42	21.42	21.42
50.00	765	385	20.00	20.00	20.00	20.00	20.00	20.00	20.00
55.00	765	385	18.59	18.59	18.59	18.59	18.59	18.59	18.59
57.77	765	385	17.82	17.82	17.82	17.82	17.82	17.82	17.82
60.00	800	400	-	17.17	17.17	17.17	17.17	17.17	17.17
61.40	800	400	-	16.77	16.77	16.77	16.77	16.77	16.77
65.00	845	425	-	-	15.75	15.75	15.75	15.75	15.75
65.10	845	425	-	-	15.72	15.72	15.72	15.72	15.72
68.85	875	440	-	-	-	14.66	14.66	14.66	14.66
70.00	915	460	-	-	-	-	14.33	14.33	14.33
72.66	915	460	-	-	-	-	13.58	13.58	13.58
75.00	950	475	-	-	-	-	-	12.92	12.92
76.53	950	475	-	-	-	-	-	12.48	12.48
80.00	990	495	-	-	-	-	-	-	11.50
80.46	990	495	-	-	-	-	-	-	11.37

See local reinforcement requirements on pages 14 to 18 and corner details on pages 19 to 21.

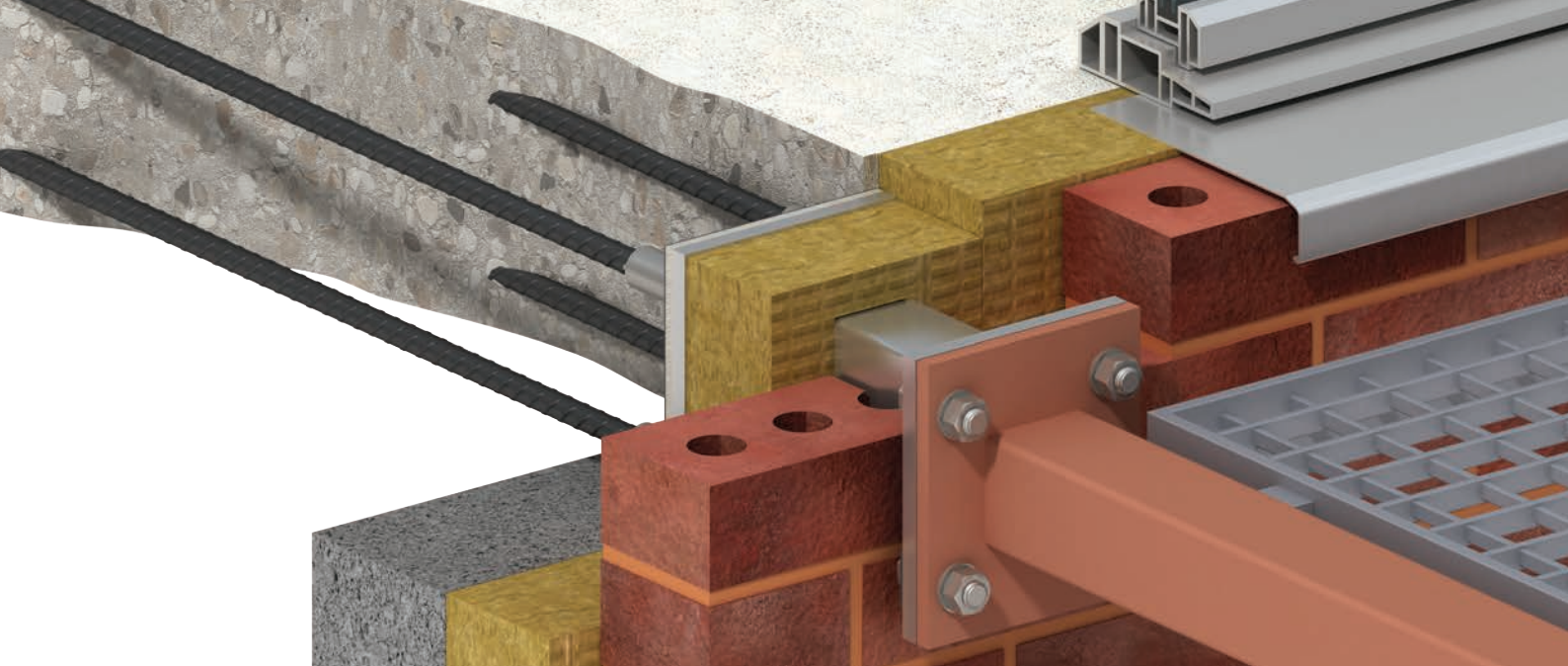

### Ancon STC20A-200

Design Shear Resistance VRd (kN)	Minimum Connector Centres (mm)	Minimum Slab Edge Distance (mm)	Design Resistance for Bending MRd (kNm)						
			225mm slab	250mm slab	275mm slab	300mm slab	325mm slab	350mm slab	375mm slab
53.78	690	345	32.86	32.86	32.86	32.86	32.86	32.86	32.86
55.00	690	345	32.56	32.56	32.56	32.56	32.56	32.56	32.56
55.98	690	345	32.32	32.32	32.32	32.32	32.32	32.32	32.32
59.68	730	365	-	31.41	31.41	31.41	31.41	31.41	31.41
60.00	770	385	-	-	31.34	31.34	31.34	31.34	31.34
63.45	770	385	-	-	30.49	30.49	30.49	30.49	30.49
65.00	800	400	-	-	-	30.11	30.11	30.11	30.11
67.27	800	400	-	-	-	29.56	29.56	29.56	29.56
70.00	840	420	-	-	-	-	28.89	28.89	28.89
71.18	840	420	-	-	-	-	28.60	28.60	28.60
75.00	880	440	-	-	-	-	-	27.67	27.67
75.14	880	440	-	-	-	-	-	27.63	27.63
79.16	920	460	-	-	-	-	-	-	26.65

### Ancon STC24A-240

Design Shear Resistance VRd (kN)	Minimum Connector Centres (mm)	Minimum Slab Edge Distance (mm)	Design Resistance for Bending MRd (kNm)						
			275mm slab	300mm slab	325mm slab	350mm slab	375mm slab	400mm slab	425mm slab
69.85	870	415	56.31	56.31	56.31	56.31	56.31	56.31	56.31
70.00	830	435	-	56.29	56.29	56.29	56.29	56.29	56.29
73.79	830	435	-	55.60	55.60	55.60	55.60	55.60	55.60
75.00	910	455	-	-	55.37	55.37	55.37	55.37	55.37
77.78	910	455	-	-	54.82	54.82	54.82	54.82	54.82
80.00	940	470	-	-	-	54.37	54.37	54.37	54.37
81.84	940	470	-	-	-	53.98	53.98	53.98	53.98
85.00	980	490	-	-	-	-	53.28	53.28	53.28
85.95	980	490	-	-	-	-	53.07	53.07	53.07
90.00	1020	510	-	-	-	-	-	52.11	52.11
90.12	1020	510	-	-	-	-	-	52.08	52.08
94.35	1060	530	-	-	-	-	-	-	51.01

### Design Example

#### Known requirements:

The Factored Ultimate Shear Force per connector,  $V_{Ed}$ , is 50kN.

The Factored Ultimate Moment per connector,  $M_{Ed}$ , is 18kNm.

The slab thickness is 275mm and the concrete grade is C32/40

The connector spacing is 750mm

#### From the tables:

✗ STC16A-150 does not give the required capacities in a 275mm thick slab

✗ STC16A-175 gives  $V_{Rd} = 50$  kN and  $M_{Rd} = 16.30$  kNm, so does not give the required capacity

✓ STC16A-200 gives  $V_{Rd} = 50$  kN,  $M_{Rd} = 18.15$  kNm and minimum connector centres < 750mm

✗ STC16A-225 gives  $V_{Rd} = 50$  kN and  $M_{Rd} = 20.00$  kNm and minimum connector centres > 750mm

# Ancon SSTC & STC Thermally Insulated Balcony Connectors

## Local Reinforcement

Additional reinforcement, local to each Ancon SSTC or STC connector, is required to guarantee that the forces are transferred between the connector and the concrete. Correct detailing in accordance with appropriate design codes and the recommendations provided here will ensure Ancon SSTC or STC connectors attain their full capacity. The tables show proposals for the type and spacing of U-Bars each side of the connector together with details of reinforcement above and below the connectors.

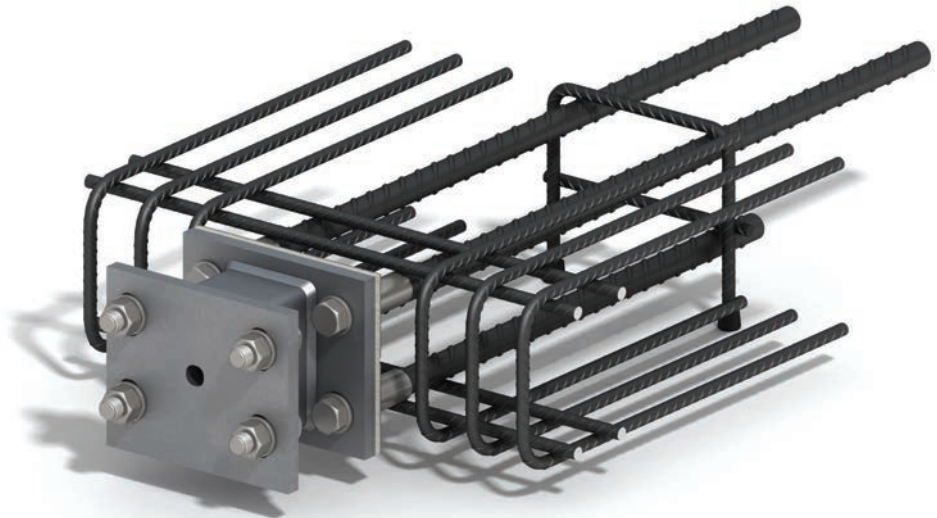

**Type 1**

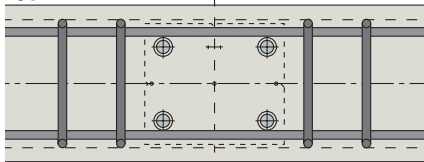

**Type 2**

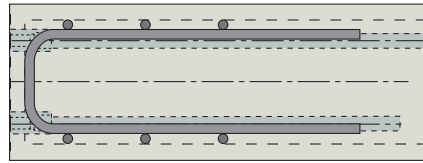
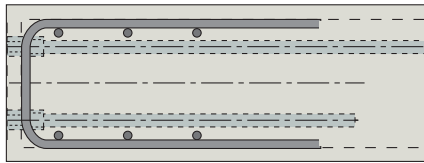
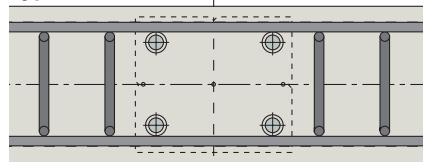

## Minimum Slab Depths for a Straight Run

Connector Reference	Minimum Slab Depth (mm)	
	Type 1 Reinforcement	Type 2 Reinforcement
SSTC/STC16A-150	200	175
SSTC/STC16A-175	225	200
SSTC/STC16A-200	250	225
SSTC/STC16A-225	275	250
STC20A-200	250	225
STC24A-240	300	275

### Notes:

Tables on pages 9 - 10 based on the following assumptions;

Grade C32/40 Concrete

Connectors assumed to be at mid depth of slab.

The maximum moment for each connector type is assumed.

Reinforcement is based on a minimum concrete cover of 25mm

Mandrel diameter for the U bars is assumed to conform to the figures given in Table 8.1N of BS EN 1992-1-1:2004

It is assumed that the U bars and the longitudinal bars are of the same diameter.

Length of longitudinal bars should be a minimum of the connector spacing + a lap length, determined in accordance with BS EN 1992-1

## Spacing of U-Bar Reinforcement

Values given in adjacent table assume:-

Cover,  $c_{nom} = 25\text{mm}$

Concrete grade C32/40

Reinforcement diameter 12mm (u-bar and longitudinal bars)

Reinforcement arrangement type 1

## U-Bar Spacing

	$e_1$ (mm)	$e_2$ (mm)
SSTC/STC16A-150	60	80
SSTC/STC16A-175	60	85
SSTC/STC16A-200	50	85
SSTC/STC16A-225	50	85
STC20A-200	50	70
STC24A-240	50	70

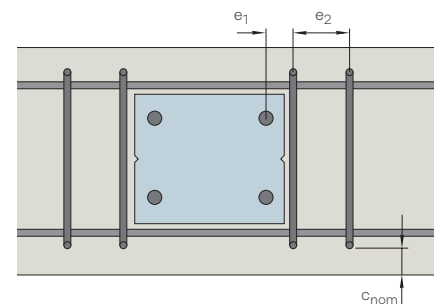

## U-Bars

SSTC/STC16A-150		U-Bar requirements for different diameter bars							
Slab Depth (mm)	H10 Bars			H12 Bars			H16 Bars		
	Number of U-Bars Each Side of Connector	Min U-Bar Leg Length (mm)	Reinforcement Configuration	Number of U-Bars Each Side of Connector	Min U-Bar Leg Length (mm)	Reinforcement Configuration	Number of U-Bars Each Side of Connector	Min U-Bar Leg Length (mm)	Reinforcement Configuration
175	2	615	Type 2	2	705	Type 2	1	875	Type 2
200	2	700	Type 1	2	770	Type 1	1	930	Type 2
225	2	745	Type 1	2	825	Type 1	1	985	Type 1
250	2	920	Type 1	2	1030	Type 1	1	1260	Type 1
275	2	975	Type 1	2	1085	Type 1	1	1305	Type 1
300	2	1020	Type 1	2	1130	Type 1	1	1360	Type 1
325	2	1075	Type 1	2	1185	Type 1	1	1405	Type 1

SSTC/STC16A-175		U-Bar requirements for different diameter bars							
Slab Depth (mm)	H10 Bars			H12 Bars			H16 Bars		
	Number of U-Bars Each Side of Connector	Min U-Bar Leg Length (mm)	Reinforcement Configuration	Number of U-Bars Each Side of Connector	Min U-Bar Leg Length (mm)	Reinforcement Configuration	Number of U-Bars Each Side of Connector	Min U-Bar Leg Length (mm)	Reinforcement Configuration
200	2	660	Type 2	2	760	Type 2	1	930	Type 2
225	2	745	Type 1	2	825	Type 1	1	975	Type 2
250	2	920	Type 1	2	1030	Type 1	1	1260	Type 1
275	2	975	Type 1	2	1085	Type 1	1	1305	Type 1
300	2	1020	Type 1	2	1130	Type 1	1	1360	Type 1
325	2	1075	Type 1	2	1185	Type 1	1	1405	Type 1
350	2	1120	Type 1	2	1230	Type 1	1	1460	Type 1

SSTC/STC16A-200		U-Bar requirements for different diameter bars							
Slab Depth (mm)	H10 Bars			H12 Bars			H16 Bars		
	Number of U-Bars Each Side of Connector	Min U-Bar Leg Length (mm)	Reinforcement Configuration	Number of U-Bars Each Side of Connector	Min U-Bar Leg Length (mm)	Reinforcement Configuration	Number of U-Bars Each Side of Connector	Min U-Bar Leg Length (mm)	Reinforcement Configuration
225	2	715	Type 2	2	805	Type 2	1	975	Type 2
250	2	920	Type 1	2	1030	Type 1	1	1250	Type 2
275	2	975	Type 1	2	1085	Type 1	1	1305	Type 1
300	2	1020	Type 1	2	1130	Type 1	1	1360	Type 1
325	2	1075	Type 1	2	1185	Type 1	1	1405	Type 1
350	2	1120	Type 1	2	1230	Type 1	1	1460	Type 1
375	2	1175	Type 1	2	1285	Type 1	1	1505	Type 1

# Ancon SSTC & STC Thermally Insulated Balcony Connectors

## U-Bars

STC16A-225		U-Bar requirements for different diameter bars							
Slab Depth (mm)	H10 Bars			H12 Bars			H16 Bars		
	Number of U-Bars Each Side of Connector	Min U-Bar Leg Length (mm)	Reinforcement Configuration	Number of U-Bars Each Side of Connector	Min U-Bar Leg Length (mm)	Reinforcement Configuration	Number of U-Bars Each Side of Connector	Min U-Bar Leg Length (mm)	Reinforcement Configuration
250	2	870	Type 2	2	1000	Type 2	1	1250	Type 2
275	2	975	Type 1	2	1085	Type 1	1	1305	Type 2
300	2	1020	Type 1	2	1130	Type 1	1	1360	Type 1
325	2	1075	Type 1	2	1185	Type 1	1	1405	Type 1
350	2	1120	Type 1	2	1230	Type 1	1	1460	Type 1
375	2	1175	Type 1	2	1285	Type 1	1	1505	Type 1
400	2	1220	Type 1	2	1330	Type 1	1	1560	Type 1

STC20A-200		U-Bar requirements for different diameter bars							
Slab Depth (mm)	H10 Bars			H12 Bars			H16 Bars		
	Number of U-Bars Each Side of Connector	Min U-Bar Leg Length (mm)	Reinforcement Configuration	Number of U-Bars Each Side of Connector	Min U-Bar Leg Length (mm)	Reinforcement Configuration	Number of U-Bars Each Side of Connector	Min U-Bar Leg Length (mm)	Reinforcement Configuration
225	3	715	Type 2	2	805	Type 2	2	975	Type 2
250	3	920	Type 1	2	1030	Type 1	2	1250	Type 2
275	3	975	Type 1	2	1085	Type 1	2	1305	Type 1
300	3	1020	Type 1	2	1130	Type 1	1	1360	Type 1
325	3	1075	Type 1	2	1185	Type 1	1	1405	Type 1
350	3	1120	Type 1	2	1230	Type 1	1	1460	Type 1
375	3	1175	Type 1	2	1285	Type 1	1	1505	Type 1

STC24A-240		U-Bar requirements for different diameter bars							
Slab Depth (mm)	H10 Bars			H12 Bars			H16 Bars		
	Number of U-Bars Each Side of Connector	Min U-Bar Leg Length (mm)	Reinforcement Configuration	Number of U-Bars Each Side of Connector	Min U-Bar Leg Length (mm)	Reinforcement Configuration	Number of U-Bars Each Side of Connector	Min U-Bar Leg Length (mm)	Reinforcement Configuration
275	3	970	Type 2	2	970	Type 2	2	1230	Type 2
300	3	1020	Type 1	2	1130	Type 1	2	1360	Type 2
325	3	1070	Type 1	2	1180	Type 1	2	1410	Type 1
350	3	1120	Type 1	2	1230	Type 1	1	1460	Type 1
375	3	1170	Type 1	2	1280	Type 1	1	1510	Type 1
400	3	1220	Type 1	2	1330	Type 1	1	1560	Type 1
425	3	1280	Type 1	2	1380	Type 1	1	1610	Type 1



## Longitudinal bars

SSTC/STC16A-150		Number of Longitudinal bars required in the top and bottom of the slab, for various connector centres												
Slab Depth (mm)	H10 Bars						H12 Bars						H16 Bars	
	600 mm	800 mm	1000 mm	1200 mm	1500 mm	2000 mm	600 mm	800 mm	1000 mm	1200 mm	1500 mm	2000 mm	600 - 2000 mm	
175	2	2	2	2	2	2	2	2	2	2	2	2	2	2
200	2	2	2	2	2	2	2	2	2	2	2	2	2	2
225	2	2	2	2	2	2	2	2	2	2	2	2	2	2
250	2	2	2	2	2	2	2	2	2	2	2	2	2	2
275	2	2	2	2	2	2	2	2	2	2	2	2	2	2
300	2	2	2	3	3	3	2	2	2	2	2	2	2	2
325	3	3	3	3	3	3	2	2	2	2	2	2	2	2

SSTC/STC16A-175		Number of Longitudinal bars required in the top and bottom of the slab, for various connector centres												
Slab Depth (mm)	H10 Bars						H12 Bars						H16 Bars	
	600 mm	800 mm	1000 mm	1200 mm	1500 mm	2000 mm	600 mm	800 mm	1000 mm	1200 mm	1500 mm	2000 mm	600 - 2000 mm	
200	2	2	2	2	2	2	2	2	2	2	2	2	2	2
225	2	2	2	2	2	2	2	2	2	2	2	2	2	2
250	2	2	2	2	2	2	2	2	2	2	2	2	2	2
275	2	2	2	2	2	2	2	2	2	2	2	2	2	2
300	2	2	2	2	2	2	2	2	2	2	2	2	2	2
325	3	3	3	3	3	3	2	2	2	2	2	2	2	2
350	3	3	3	3	3	3	2	2	2	2	2	3	2	2

SSTC/STC16A-200		Number of Longitudinal bars required in the top and bottom of the slab, for various connector centres												
Slab Depth (mm)	H10 Bars						H12 Bars						H16 Bars	
	600 mm	800 mm	1000 mm	1200 mm	1500 mm	2000 mm	600 mm	800 mm	1000 mm	1200 mm	1500 mm	2000 mm	600 - 2000 mm	
225	2	2	2	2	2	2	2	2	2	2	2	2	2	2
250	2	2	2	2	2	2	2	2	2	2	2	2	2	2
275	2	2	2	2	2	2	2	2	2	2	2	2	2	2
300	2	2	2	3	3	3	2	2	2	2	2	2	2	2
325	3	3	3	3	3	3	2	2	2	2	2	2	2	2
350	3	3	3	3	3	3	2	2	2	2	2	3	2	2
375	3	3	3	3	3	3	2	3	3	3	3	3	3	2

# Ancon SSTC & STC Thermally Insulated Balcony Connectors

## Longitudinal bars

SSTC/STC16A-225		Number of Longitudinal bars required in the top and bottom of the slab, for various connector centres												
Slab Depth (mm)	H10 Bars						H12 Bars						H16 Bars	
	600 mm	800 mm	1000 mm	1200 mm	1500 mm	2000 mm	600 mm	800 mm	1000 mm	1200 mm	1500 mm	2000 mm	600 - 2000 mm	
250	2	2	2	2	2	2	2	2	2	2	2	2	2	2
275	2	2	2	2	2	2	2	2	2	2	2	2	2	2
300	2	2	2	3	3	3	2	2	2	2	2	2	2	2
325	3	3	3	3	3	3	2	2	2	2	2	2	2	2
350	3	3	3	3	3	4	2	2	2	2	2	3	2	2
375	3	3	4	4	4	4	2	3	3	3	3	3	2	2
400	4	4	4	4	4	4	3	3	3	3	3	3	2	2

SSTC/STC20A-200		Number of Longitudinal bars required in the top and bottom of the slab, for various connector centres												
Slab Depth (mm)	H10 Bars						H12 Bars						H16 Bars	
	600 mm	800 mm	1000 mm	1200 mm	1500 mm	2000 mm	600 mm	800 mm	1000 mm	1200 mm	1500 mm	2000 mm	600 - 2000 mm	
225	2	2	2	2	2	2	2	2	2	2	2	2	2	2
250	2	2	2	2	2	2	2	2	2	2	2	2	2	2
275	2	2	2	2	2	2	2	2	2	2	2	2	2	2
300	2	2	2	2	3	3	2	2	2	2	2	2	2	2
325	3	3	3	3	3	3	2	2	2	2	2	2	2	2
350	3	3	3	3	3	4	2	2	2	2	2	3	2	2
375	3	3	3	4	4	4	2	2	3	3	3	3	2	2

SSTC/STC24A-240		Number of Longitudinal bars required in the top and bottom of the slab, for various connector centres												
Slab Depth (mm)	H10 Bars						H12 Bars						H16 Bars	
	600 mm	800 mm	1000 mm	1200 mm	1500 mm	2000 mm	600 mm	800 mm	1000 mm	1200 mm	1500 mm	2000 mm	600 - 2000 mm	
275	2	2	2	2	2	2	2	2	2	2	2	2	2	2
300	2	2	2	2	3	3	2	2	2	2	2	2	2	2
325	3	3	3	3	3	3	2	2	2	2	2	2	2	2
350	3	3	3	3	3	4	2	2	2	2	2	3	2	2
375	3	3	3	4	4	4	2	2	3	3	3	3	2	2
400	4	4	4	4	4	4	3	3	3	3	3	3	2	2
425	4	4	4	4	4	4	3	3	3	3	3	3	2	2

## Corner Details

Standard Ancon SSTC/STC corner units are available which offset the position of the anchor bars on adjacent connectors to eliminate a reinforcement clash.

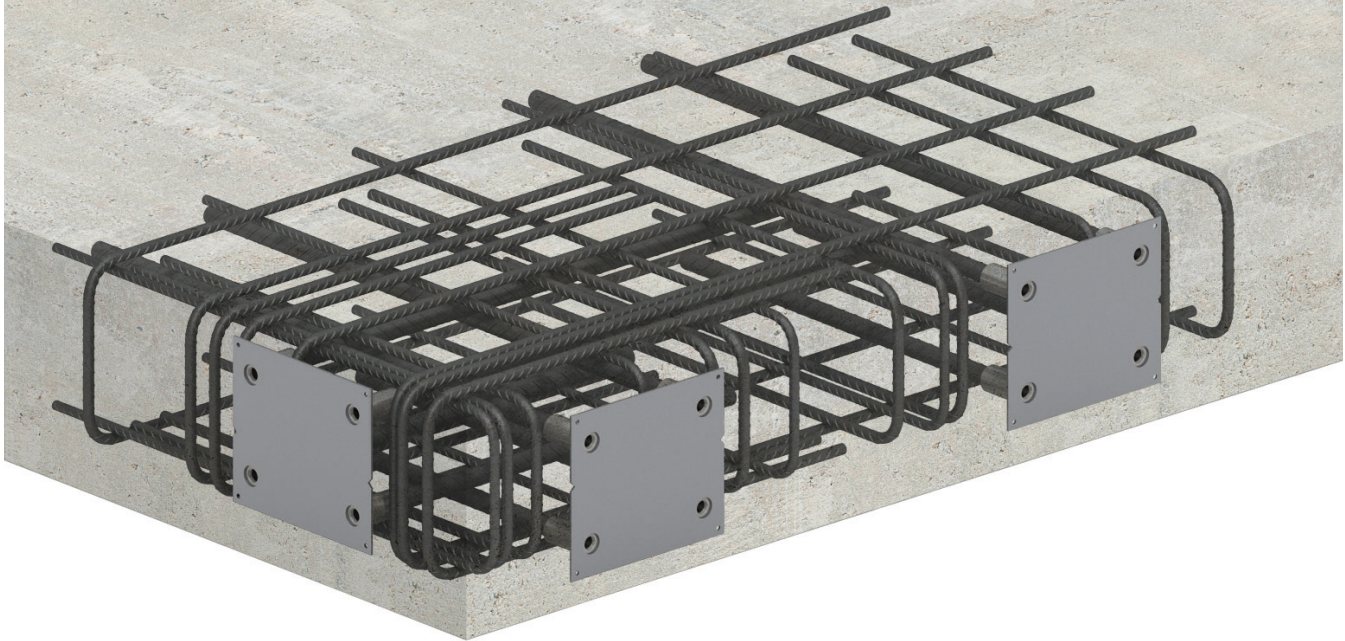

The corresponding bracket assemblies feature an extended fixing plate on one side to bring the balcony fixing position back in line with the standard Ancon SSTC/STC connectors used in the rest of the slab.

Due to the offset, the minimum slab depth for these corner units is deeper than that for a straight run and is given in the table. The offset also affects the unit performance. The ten graphs on pages 12 and 13 show the moment and shear resistance for each SSTC/STC corner unit in relation to the distance from the corner and also when the loads become the same as for the standard connector.

The side notches in an SSTC/STC nailplate are used to indicate the fixing line, normally the centreline of the slab. On SSTC/STC corner units, these notches are offset to create the difference in fixing height at the corner.

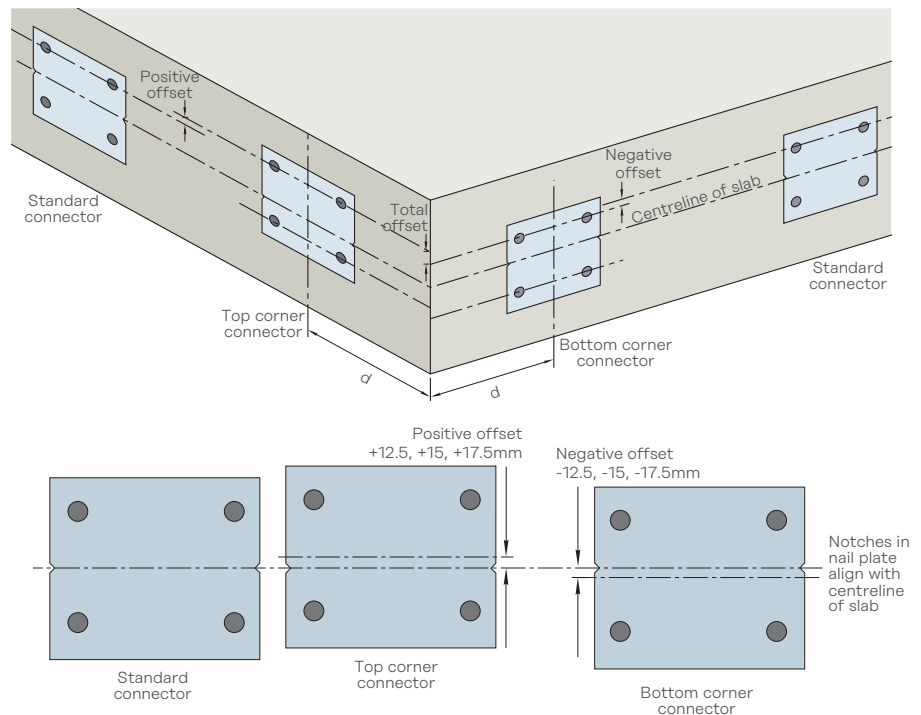

### Minimum Slab Depths at Corners

Connector Reference	Minimum Slab Depth (mm)
SSTC/STC16A-150	225
SSTC/STC16A-175	250
SSTC/STC16A-200	275
SSTC/STC16A-225	300
STC20A-200	275
STC24A-240	325

### Corner Unit Offsets

Connector	Offset per Corner Connector (mm)	Total System Offset (mm)
SSTC/STC16A	+/- 12.5	25
STC20A	+/- 15.0	30
STC24A	+/- 17.5	35

# Ancon SSTC & STC Thermally Insulated Balcony Connectors

**Ancon STC16A-150 Corner Units**

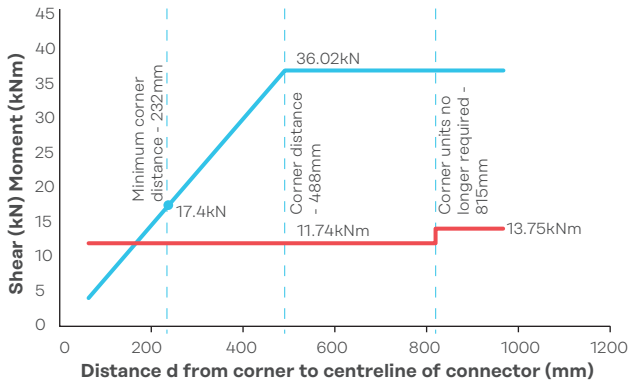

**Ancon STC16A-200 Corner Units**

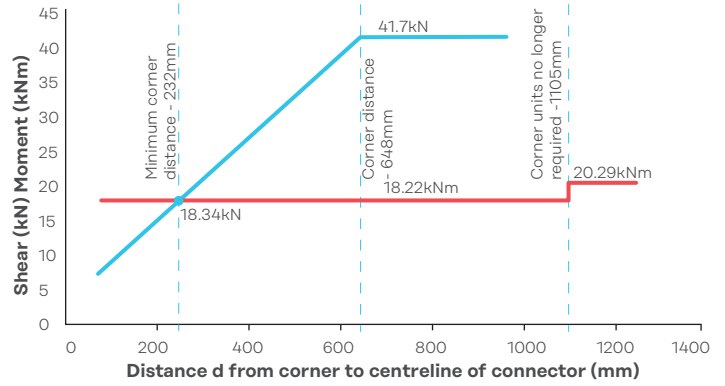

**Ancon STC16A-175 Corner Units**

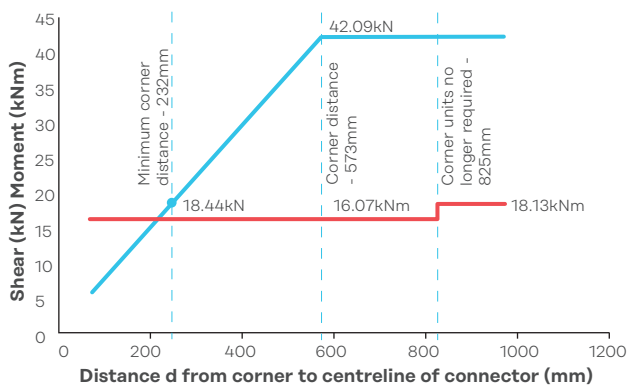

**Ancon STC16A-225 Corner Units**

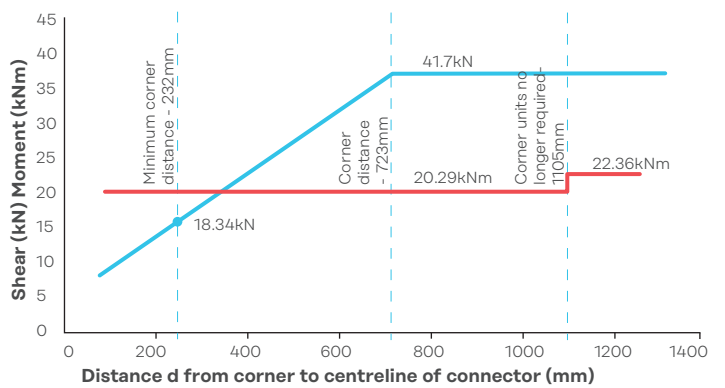

**Ancon STC20A-200 Corner Units**

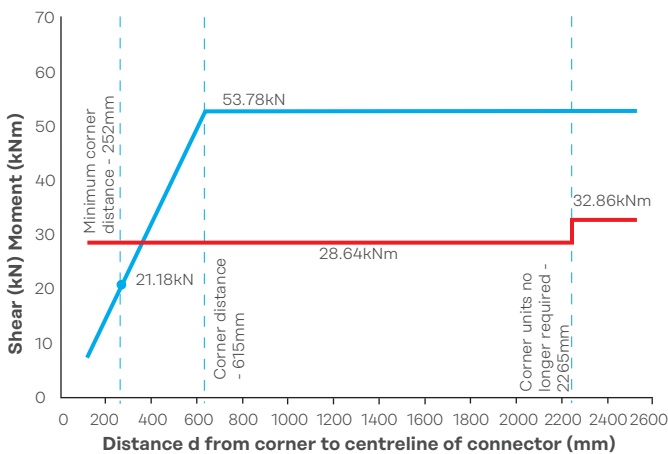

**Ancon STC24A-240 Corner Units**

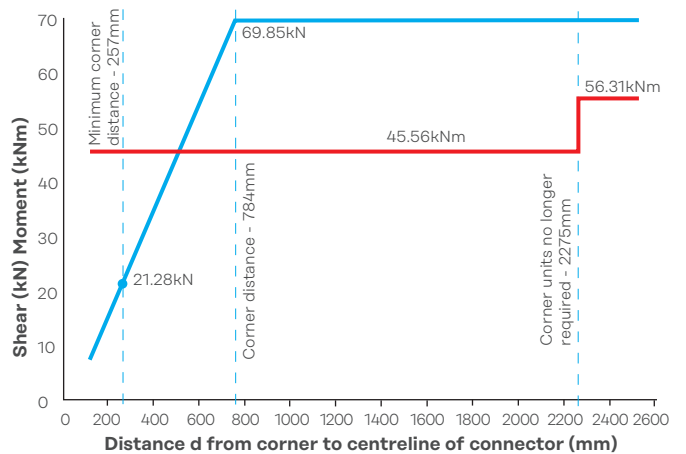

— Min VRd (kN)  
— Max MRd (kNm)

**Ancon SSTC16A-150 Corner Units**

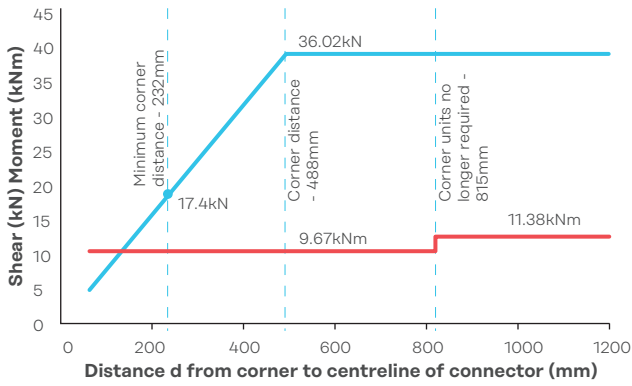

**Ancon SSTC16A-200 Corner Units**

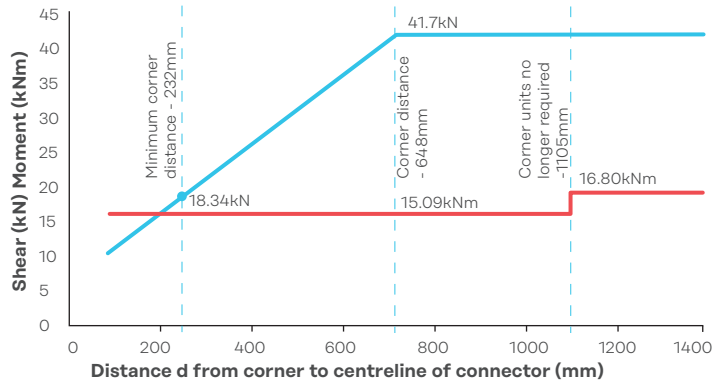

**Ancon SSTC16A-175 Corner Units**

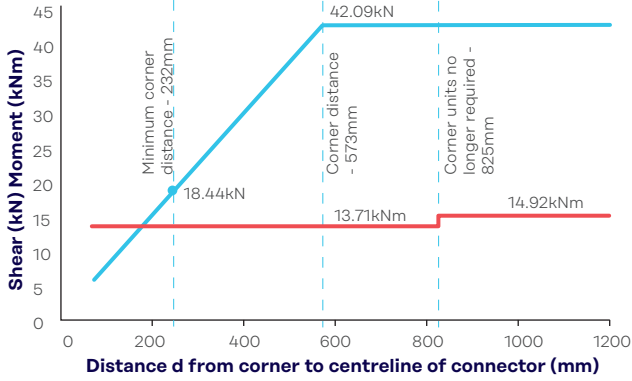

**Ancon SSTC16A-225 Corner Units**

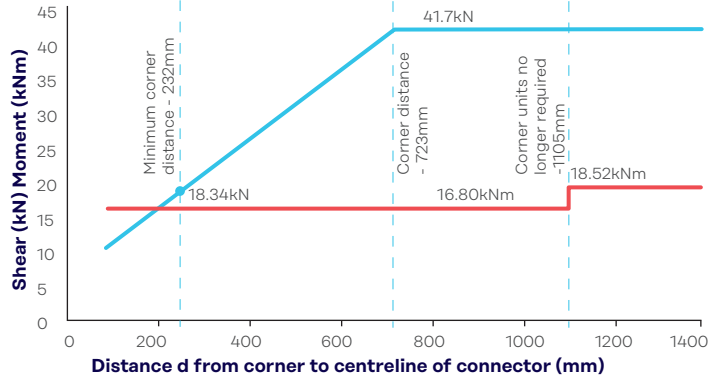

— Min VRd (kN)  
— Max MRd (kNm)

**Fire Resistance Considerations**

Should fire resistance be a requirement of the project, the balcony bracket and fixings must be adequately protected: this should be in the form of a site-applied intumescent coating or by fire board encapsulation. A fire protection specialist should be consulted for advice.

# Ancon SSTC & STC Thermally Insulated Balcony Connectors

## Installation

Ancon SSTC/STC balcony connectors are quick and easy to install. Installation is a two phase process. The SSTC/STC system consists of two components; a cast-in anchorage and a fabricated bracket with thermal plate.

### Cast-in Anchorage

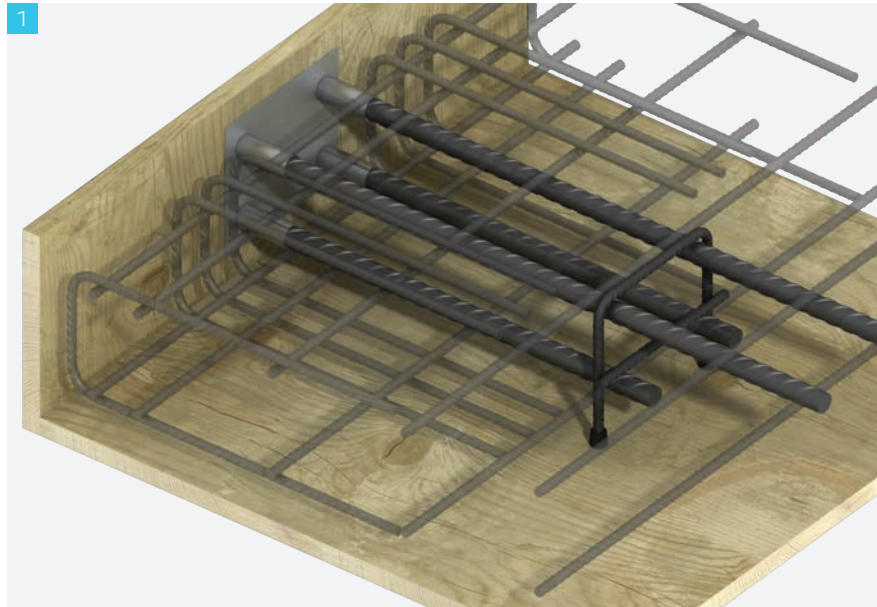

Nail the assembly to the formwork. The end of the reinforcement cage should be supported on spacers or tied to adjacent slab reinforcement. Fix secondary reinforcement (consult technical literature and project drawings for details) and cast concrete. Allow to cure and strike formwork.

### Bracket/Thermal Plate Section



Remove and discard plastic plugs from couplers and nylon nuts from bracket. Offer up thermal plate and then the fabricated bracket. Labels on the connector identify the balcony and concrete slab side, as well as the orientation of the connector. Install the four stainless steel setscrews and washers, and hand tighten.

Tighten to the correct torque using a calibrated hydraulic torque wrench according to the reference table below. The thermal plate is now sandwiched between the bracket and the concrete.

Connector	Stainless Steel Setscrew	Tightening Torque
SSTC/STC16A	M16, Length 40mm	170Nm
STC20A	M20, Length 50mm	305Nm
STC24A	M24, Length 60mm	530Nm

## Balcony

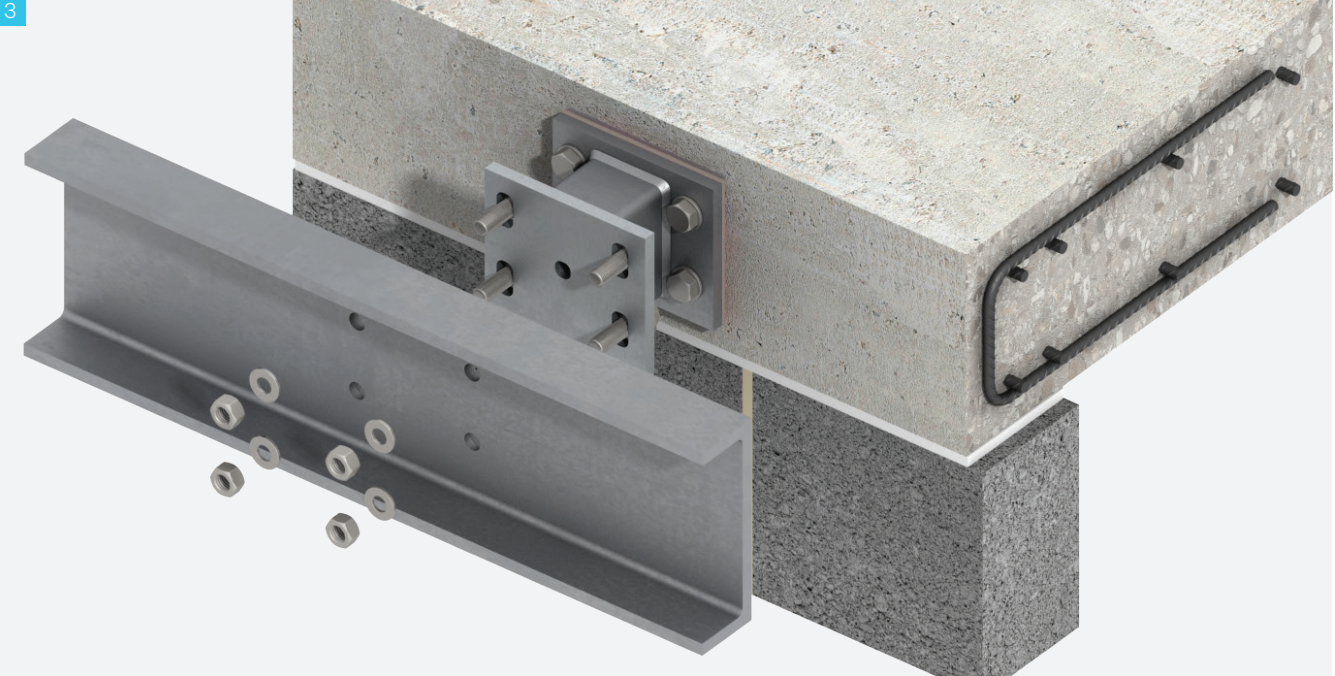

Offer up the steel balcony and connect to the SSTC/STC bracket with the four galvanized hex head setscrews as follows:

- The top bolts should have the two galvanized square plate washers over the plain slots in the SSTC/STC connector
- The bottom bolts should have the two galvanized serrated washers over the serrated slots in the SSTC/STC connector, orientated to mate and not turned at an angle or installed using the plain side
- Four galvanized washers are provided for the balcony side of the connection, however if the balcony is slotted a plate washer should be used
- The balcony should be levelled vertically using the adjustment provided by the vertical slots in the connector
- In order to guarantee adequate positioning of the balcony steelwork, care must be taken to ensure that the concrete face is vertically level. Should the concrete face be out of plumb, full face tapered shims should be used between the bracket and thermal plate for angular adjustment. We can advise on this if necessary
- Adjustment should not be made between the connector and the thermal break or between the thermal break and the concrete slab edge
- Hand tighten the four connection bolts and then using a calibrated hydraulic torque wrench and referencing the table below

Connector	Galvanised Hex Head Setscrew	Tightening Torque
SSTC/STC16A	M16, Length 60mm	170Nm
STC20A	M20, Length 75mm	325Nm
STC24A	M24, Length 90mm	565Nm

# Ancon SSTC & STC Thermally Insulated Balcony Connectors

## Other Leviat Products

### Halfen HIT Concrete-to-Concrete Balcony Connectors

Our thermally insulated connectors minimise heat loss at balcony locations while maintaining structural integrity. They provide a thermal break and, as a critical structural component, transfer moment, shear, tension and compression forces. Standard HIT Elements fulfill the requirements for the highest fire protection classification REI 120. Offering 2 hours fire resistance.

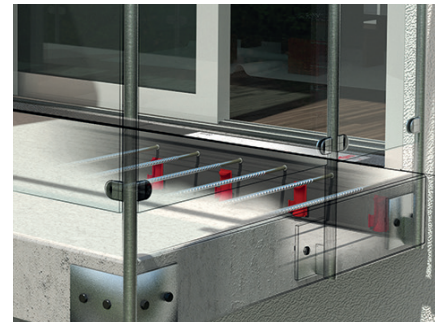

### Ancon Steel-to-Steel Balcony Connectors

The Ancon STS range is a compact thermal break, typically used for connecting steel balconies to structural steel frames but is equally suitable for other steel-to-steel applications. The connectors are formed exclusively from materials of European Classification A1 and A2-s1,d0 which are fully compliant with the combustibility requirements of the Building (Amendment) Regulation 2018 – the Government's ban on combustible materials in high-rise construction. The CE-marked fabricated compression component can be manufactured in either stainless steel (SSTC) or hot dipped galvanised steel (STC). Thermal modelling of a typical application showed a reduction in heat loss of almost 50% compared to a direct steel connection.



### Ancon Low Thermal Conductivity Wall Ties

Wall Ties are an essential element in the strength and stability of a cavity wall, however, by crossing the insulated cavity they act as a thermal bridge between the internal and external leaves. Leviat manufactures a range of low thermal conductivity Ancon Wall Ties to minimise the effects of thermal bridging. The Ancon range offers reduced heat transmittance whilst continuing to meet the structural performance requirements of multi-storey and wide cavity construction. Products include slender Ancon Staifix stainless steel wire ties and BBA-approved Ancon Teplo wall ties manufactured from basalt fibres with a thermal conductivity of just 0.7WmK.



### Ancon Masonry Support Systems

Masonry cladding on concrete or steel frames is normally supported from stainless steel support systems. The standard Ancon Optima System and the bespoke Ancon MDC System create a continuous angle to support the outer leaf of masonry. Solutions are available to support special masonry features such as curves, arches and soffits. Ancon support Brackets can be supplied with a fire-rated thermal break to minimise heat loss through cold bridging at the interface with the structure. The standard thermal break is shaped like a keyhole shim to allow it to be located quickly on site.

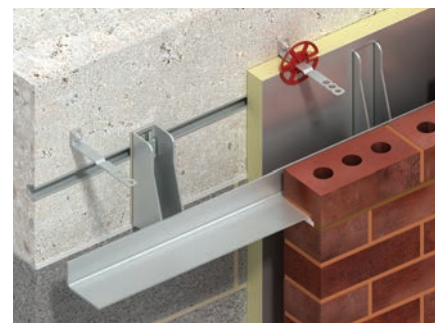

### Halfen Tension Systems

Tie bars are increasingly being used in structures and buildings as an architectural as well as a structural element. Halfen Tension Systems comprise a range of components which can be supplied in carbon steel or stainless steel in a variety of sizes and finishes. A variety of assemblies can be created from simple tie bars to complex bracing systems involving several bars joined at one point.







**Leviat<sup>®</sup>**  
A CRH COMPANY

Innovative engineered products and construction solutions that allow the industry to build safer, stronger and faster.



## Contact Leviat locally

For more information on the products featured here, please contact Leviat:

### United Kingdom

#### Sheffield

President Way,

President Park,

Sheffield S4 7UR

Tel: +44 - 114 275 5224

Email: [info.uk@leviat.com](mailto:info.uk@leviat.com)

# Contact Leviat worldwide

## Australia

98 Kurrajong Avenue,  
Mount Druitt, Sydney, NSW 2770  
Tel: +61 - 2 8808 3100  
Email: [info.au@leviat.com](mailto:info.au@leviat.com)

## Austria

Leonard-Bernstein-Str. 10  
Saturn Tower, 1220 Wien  
Tel: +43 - 1 - 259 6770  
Email: [info.at@leviat.com](mailto:info.at@leviat.com)

## Belgium

Industrielaan 2  
1740 Ternat  
Tel: +32 - 2 - 582 29 45  
Email: [info.be@leviat.com](mailto:info.be@leviat.com)

## China

Room 601 Tower D,  
Vantone Centre  
No. A6 Chao Yang Men Wai Street  
Chaoyang District  
Beijing P.R. China 100020  
Tel: +86 - 10 5907 3200  
Email: [info.cn@leviat.com](mailto:info.cn@leviat.com)

## Czech Republic

Business Center Šafránková  
Šafránková 1238/1  
155 00 Praha 5  
Tel: +420 - 311 - 690 060  
Email: [info.cz@leviat.com](mailto:info.cz@leviat.com)

## Finland

Vädursgatan 5  
412 50 Göteborg / Sweden  
Tel: +358 (0)10 6338781  
Email: [info.fi@leviat.com](mailto:info.fi@leviat.com)

## France

6, Rue de Cabanis  
FR 31240 L'Union  
Toulouse  
Tel: +33 - 5 - 34 25 54 82  
Email: [info.fr@leviat.com](mailto:info.fr@leviat.com)

## Germany

Liebigstrasse 14  
40764 Langenfeld  
Tel: +49 - 2173 - 970 - 0  
Email: [info.de@leviat.com](mailto:info.de@leviat.com)

## India

309, 3rd Floor  
Orion Business Park  
Ghodbunder Road  
Kapurbawdi, Thane West,  
Thane, Maharashtra 400607  
Tel: +91 - 22 2589 2032  
Email: [info.in@leviat.com](mailto:info.in@leviat.com)

## Italy

Via F.lli Bronzetti 28  
24124 Bergamo  
Tel: +39 - 035 - 0760711  
Email: [info.it@leviat.com](mailto:info.it@leviat.com)

## Malaysia

28 Jalan Anggerik Mokara 31/59  
Kota Kemuning,  
40460 Shah Alam Selangor  
Tel: +603 - 5122 4182  
Email: [info.my@leviat.com](mailto:info.my@leviat.com)

## Netherlands

Oostermaat 3  
7623 CS Borne  
Tel: +31 - 74 - 267 14 49  
Email: [info.nl@leviat.com](mailto:info.nl@leviat.com)

## New Zealand

2/19 Nuttall Drive, Hillsborough,  
Christchurch 8022  
Tel: +64 - 3 376 5205  
Email: [info.nz@leviat.com](mailto:info.nz@leviat.com)

## Norway

Vestre Svanholmen 5  
4313 Sandnes  
Tel: +47 - 51 82 34 00  
Email: [info.no@leviat.com](mailto:info.no@leviat.com)

## Philippines

2933 Regus, Joy Nostalg,  
ADB Avenue, Ortigas Center  
Pasig City  
Tel: +63 - 2 7957 6381  
Email: [info.ph@leviat.com](mailto:info.ph@leviat.com)

## Poland

Ul. Obornicka 287  
60-691 Poznań  
Tel: +48 - 61 - 622 14 14  
Email: [info.pl@leviat.com](mailto:info.pl@leviat.com)

## Singapore

14 Benoi Crescent  
Singapore 629977  
Tel: +65 - 6266 6802  
Email: [info.sg@leviat.com](mailto:info.sg@leviat.com)

## Spain

Polígono Industrial Santa Ana  
c/ Ignacio Zuloaga, 20  
28522 Rivas-Vaciamadrid  
Tel: +34 - 91 632 18 40  
Email: [info.es@leviat.com](mailto:info.es@leviat.com)

## Sweden

Vädursgatan 5  
412 50 Göteborg  
Tel: +46 - 31 - 98 58 00  
Email: [info.se@leviat.com](mailto:info.se@leviat.com)

## Switzerland

Grenzstrasse 24  
3250 Lyss  
Tel: +41 (0)800 22 66 00  
Email: [info.ch@leviat.com](mailto:info.ch@leviat.com)

## United Arab Emirates

RA08 TB02, PO Box 17225  
JAFZA, Jebel Ali, Dubai  
Tel: +971 (0)4 883 4346  
Email: [info.ae@leviat.com](mailto:info.ae@leviat.com)

## United Kingdom

President Way,  
President Park,  
Sheffield S4 7UR  
Tel: +44 - 114 275 5224  
Email: [info.uk@leviat.com](mailto:info.uk@leviat.com)

## USA / Canada

6467 S Falkenburg Road  
Riverview, FL 33578  
Tel: (800) 423-9140  
Email: [info.us@leviat.us](mailto:info.us@leviat.us)

For countries not listed  
Email: [info@leviat.com](mailto:info@leviat.com)

## Notes regarding this document

© Protected by copyright. The information in this publication is based on state-of-the-art technology at the time of publication. In every case, project working details should be entrusted to appropriately qualified and experienced persons. Leviat shall not accept liability for the accuracy of the information in this document or for any printing errors. We reserve the right to make technical and design changes at any time. With a policy of continuous product development, Leviat reserves the right to modify product design and specification at any time.

